

ARTICLE III

GENERAL PROVISIONS OF THE CONTRACT

- III.1 GENERAL
- III.2 BIDDING AND CONTRACT EXECUTION
- III.3 CONTRACTS
- III.4 SUB-CONTRACTS
- III.5 INSURANCE
- III.6 PLANS AND SPECIFICATIONS
- III.7 ENGINEERING SUPERVISION
- III.8 CONTRACTOR'S WORKING CONDITIONS
- III.9 MEASUREMENT AND PAYMENT
- III.10 WORK ELIGIBILITY STATUS VERIFICATION
- III.11 TITLE VI NON-DISCRIMINATION PROGRAM
- III.12 CLEAN UP
- III.13 SEDIMENT & EROSION CONTROL, AND POLLUTION PREVENTION

ARTICLE III

GENERAL PROVISIONS OF THE CONTRACT

III.1 GENERAL

- A. The provisions of this section are of a general nature and are intended to apply to contract work of all types. Whenever any of these provisions do not apply to a specific contract, the exceptions will be noted in the Article II Special Provisions attached to the specific contract. In case of any conflicts between Article III General Provisions and Article II Special Provisions, the Article II Special Provisions shall govern.

III.2 BIDDING AND CONTRACT EXECUTION

- A. Definitions: The following terms as used in these contract documents are respectfully defined as follows:
- a. Contract - The contract documents consisting of the Agreement, the General Provisions of the Contract, Special Provisions of the Contract, the Drawings and Specifications, including all modifications thereof, incorporated in the documents before their execution.
 - b. Owner, City, Mayor, or City Council - The governing body of the municipality which is the contracting party initiating the project as set forth in the contract.
 - c. Contractor - The party or parties entering into contract for the performance of the work and who is subject to the terms of said contract. Also the agents, employees, workmen, or assignees of said contractor.
 - d. Subcontractor - A person, firm, or corporation, other than the Contractor, supplying labor and materials, or labor only on work considered in this contract.
 - e. Engineer, City Engineer - The Engineer in charge or his duly authorized assistants, acting under authority of the City.
 - f. Work - All work including materials, labor, supervision, use of tools necessary to complete the construction called for in the contract in full compliance with the terms of the contract.
 - g. Project - The entire improvement proposed by the Owner to be constructed in whole or in part pursuant to that within the contract.
 - h. Surety - The person, firm or corporation that has executed, as surety, the Contractors Performance Bond, securing the performance of that within the contract.

- B. Site Examination: Bidders shall inform themselves of the conditions under which the work is to be performed, concerning the site of the work, the structure of the ground, obstacles which may be encountered and all other relevant matters concerning the work to be performed. Where test boring logs indicating underground conditions are shown on the plans, such logs shall be considered only as indicative of conditions as observed at the time and place indicated, and neither the Engineer nor the Owner shall be held responsible for any variance in conditions encountered at the time of actual construction. It shall be the responsibility of the Contractor to satisfy himself by such methods as he deems necessary prior to the letting as to underground structures and obstacles to be encountered.
- C. The Contractor to whom a contract is awarded will not be allowed any extra compensation by reason of any matter or thing concerning which he might fully have informed himself, prior to the bidding.
- D. The successful Contractor will be required to employ, so far as possible, such methods and means in the carrying out of his work as will not cause any interruptions or interference with any other Contractor.
- E. Specification Requirements: The bidder is expected to base his bid on materials and equipment complying fully with the plans and specifications, and in the event he names in his bid, materials or equipment which do not conform, he will be responsible for furnishing materials and equipment which fully conform at no change in his bid price.
- F. Before submitting a proposal, each Contractor should read the complete specifications and plans, including all related documents contained herein, all of which contain provisions applicable not only to the successful bidder, but also to his subcontractor.
- G. Statement of Bidders Plan and Financial Condition: Each bidder may submit with his bid, and in any event the Owner may, after bids are opened and prior to award of contract, require any bidder to submit the following data:
- a. A statement that the bidder maintains a permanent address thereof.
 - b. A statement of the equipment which the bidder proposes to use on the project, together with a statement noting that equipment previously mentioned which the bidder owns and that which he does not own, but is certain he will be able to rent or otherwise procure for use on the project.
 - c. A financial statement, duly sworn to in a form approved by the Owner, listing assets and liabilities.
 - d. A statement listing projects of similar nature which the bidder has constructed, or in the construction of which the bidder was actively engaged in a responsible capacity.

- H. Conditions in Bidder's Proposals: A bidder shall not stipulate in his proposal any conditions not contained in the Form of Proposal contained in the Contract Documents.
- I. Quantities: Bidders must satisfy themselves by personal examination of the locations of the proposed work and by such other means as they may prefer as to the correctness of any quantities listed in the proposal, and shall not after submission of their proposal dispute or complain of such estimate, nor assert that there was any misunderstanding in regard to the nature or amount of work to be done.
- J. Copies of Documents: Each bidder will be furnished with one copy of the specifications and related documents. A duplicate set of Proposal Forms will be furnished for the bidders. Bid Proposals will be accepted on the duplicate copy.
- K. Data Sheets: Where data sheets concerning equipment to be furnished are included in the Specification Documents as a part of the proposal, the bidder shall furnish the required information by filling in the data sheets complete in every detail. In the event that such data sheets are insufficient, or do not readily lend themselves to the correct description of the equipment, the bidder shall file with the bid additional statements setting out the necessary information. Failure to furnish such information as is required on the data sheets may be cause for the bid to be rejected.
- L. Preparation of Proposal:
- a. Each proposal shall be firmly sealed in an envelope labeled (Contract Proposal, _____ 'Project' _____), and addressed (Mayor and City Council, City of Norfolk, Nebraska). All bids are to be made only on forms of proposal furnished by the Owner.
 - b. All conditions of these Standard Specifications apply, even though the proposal is not attached to same.
 - c. If the proposal calls for a lump sum bid, then the total bid prices shall be written by both words and figures, and in case of conflict, the former (written in words) will apply, or the bid may be rejected.
 - d. If unit bids are called for, the unit prices may be written in numbers and any number that is not plainly written may be cause for the bid to be rejected. In the event of a discrepancy between unit bid prices and extensions, the unit bid prices shall govern, or the proposal may be rejected.
 - e. No bid will be accepted which does not contain adequate or reasonable price for each and every item provided for in the bidding schedule.
 - f. No alterations or interlineations will be permitted unless made before submission and initialed and dated.

g. The affidavit attached to the proposal for this contract shall be filled out and submitted with said proposal or the bid shall be declared void.

M. Bid Security: No proposal will be received unless accompanied by a certified check as defined in the Advertisement for Bids, payable to the Owner as a guarantee that if the bid is accepted, the bidder will execute and file the proposed contract and bond within ten (10) days from the date of the award of the contract. Bid bonds will be accepted as security in lieu of certified checks only if specifically permitted in the Advertisement for Bids. On failure of the successful bidder to execute the contract and bond, he shall forfeit the deposit as agreed as liquidated damages, and the acceptance of the bid will be contingent upon the fulfillment of this requirement by the bidder. The bid security of the three lowest formal bidders for each contract may be held until the contract is executed and approved and then returned to the bidders. The balance of bid securities submitted will be returned within three (3) days after the opening of bids.

N. Bid Security Submitted with Proposal:

The bid security (i.e. bid bond or certified check) as outlined in Articles I and III of these specifications shall be submitted in a **separate envelope** along with the proposal. The bid security shall be clearly marked and accessible without needing to open the envelope containing the proposal. Any proposal that does not have bid security as outlined above will not be accepted and is subject to rejection.

O. Signing of Bids:

a. Bids which are not signed by individuals making them should have attached hereto a power of attorney evidencing authority to sign the bid in the name of the person for whom it is signed.

b. Bids which are signed for a co-partnership should be signed by all the co-partners or by an attorney-in-fact. If signed by an attorney-in-fact, there should be attached to the bid a power of attorney evidencing authority to sign the bid.

c. Bids which are signed for a corporation should have the correct corporate name thereof signed in handwriting or typewritten, and the signature of the president or other authorized officer of the corporation should be manually written below the written or typewritten corporate name following the word "By"

d. If bids are signed for any other legal entity, the authority of the person signing for such legal entity should be attached to the bid.

P. Withdrawal of Bids: Any bidder may withdraw his bid at any time prior to the scheduled closing time for the receipt of bids, but no bid shall be withdrawn for a period of 60 days after the scheduled closing time for the receipt of bids.

- Q. Alternates: If the proposal forms include alternates, each bidder may bid on one or more alternates at his own discretion unless directed elsewhere in these specifications. Each bidder must submit such special data, if any, in respect to such alternates which any section of the contract documents require to be submitted with each bid.
- R. Supplemental Unit Prices: On a lump sum contract, or partial lump sum contract, the Owner reserves the right to reject any or all supplemental unit prices which it deems to be excessive or unreasonable. In cases where any part or all of the bidding is to be received on a unit price basis, the quantities stated are not intended to govern. The quantities stated, on which unit prices are so invited are approximate only, and each bidder will be required to make his own estimates of amounts, and to calculate his unit price bid accordingly. Bids will be compared on the basis of the stated number of units in the proposal form. Such estimated quantities, while made from the best information available, are approximate only. Payment on the contract will be based on actual number of units installed on the completed work.

III.3 CONTRACTS

- A. Award of Contract: Contracts shall be awarded to the lowest responsible and responsive bidder. In determining “lowest responsible bidder”, in addition to price, the following shall be considered by the Owner:
1. The ability, capacity, and skill of the bidder to perform the contract required;
 2. The character, integrity, reputation, judgment, experience, and efficiency of the bidder;
 3. Whether the bidder can perform the contract within the time specified;
 4. The quality of performance of previous contracts;
 5. The previous and existing compliance by the bidder with laws and ordinances relating to the contract;
 6. Such other information as may be secured having a bearing on the decision to award the contract.

A “responsive bidder” shall be defined as a person or company who has submitted a bid which conforms in all material respects to the “Invitation for Bids”.

When the award is not given to the lowest bidder, a full and complete statement of the reasons for award to another bidder shall be prepared by the Owner and filed with other papers relating to the transaction.

- B. Definition of Award: The contract shall be deemed to have been awarded when formal notice of award shall have been duly served upon the intended awardee (that is, the bidder to whom the Owner contemplates awarding the contract) by some officer or agent of the Owner duly authorized to give such notice.
- C. Definition of Notice: Where in any section of the Contract Document there is any provision in respect to the giving of any notice, such notice shall be deemed to have been given (as to the Owner) when written notice shall be delivered to the Engineer of the Owner, or shall have

been placed in the United States mails addressed to the Chief Executive Officer of the Owner, at the place where the bids or proposals for the contract were opened; (as to the Contractor) when a written notice shall be delivered to the chief representative of the Contractor at the site of the project to be constructed under the contract or when such written notice shall have been placed in the United States mails addressed to the Contractor at the place stated in the papers prepared by him to accompany his proposal as the address of his permanent place of business; (as to the Surety) on the performance of bond when a written notice is the home office of such Surety, and when two (2) copies of such notice shall have been filed with the Owner.

- D. Execution of Contracts and Bonds: Each contract must be executed in three (3) original counterparts and no more and there shall be executed original counterparts of the Contractor's performance bond in equal number to the executed original counterparts of the Contract, and there shall be executed original counterparts of the Contractor's certificate of Proof of Insurance Carriage in equal number to the executed original counterparts of the Contract. One copy of such executed documents will be retained by the Owner, the second will be delivered to the Contractor and the third to the Engineer. The costs of executing the contract, bonds, and proof of insurance certificates, including all notarial fees and expense are to be paid by the Contractor to whom the contract is awarded.
- E. Contract Security: The Contractor shall furnish a surety bond, or bonds, (form attached) in any amount at least equal to 100 percent of contract prices as security for the faithful performance of this contract and for the payment of all persons performing labor and furnishing materials in connection with this contract. Said bond shall also be complete surety for all guarantees of materials and workmanship required elsewhere in these specifications.
- F. Schedule of Unit Prices: Promptly following the execution of the contract documents for all lump sum contracts, the Contractor shall prepare and transmit to the Engineer two (2) copies of an itemized breakdown showing the unit quantities of each major construction item and the corresponding unit prices. Such unit prices shall contain all costs including profit of each item complete in place. The total cost of all the items shall equal the contract price for the project. This breakdown when approved by the Engineer will be used primarily in determining payment due the Contractor on periodical estimates. If in the opinion of the Engineer, any unit price submitted by the Contractor is unbalanced, a detailed breakdown of the items contained in the unit will be required.
- G. For contracts bid on a unit price basis, unit bid prices for substantially completed work will be used in determining payment due the Contractor on periodical estimates. Partially completed unit will not be paid for in periodical estimates.

III.4 SUBCONTRACTS

- A. Subcontracts: The Contractor shall notify the Owner and the Engineer in writing of the names of the subcontractors proposed on the contract, and shall not employ any subcontractor that the Owner or the Engineer objects to as incompetent or unfit.

Revised 07/2019

- B. The Contractor agrees to be fully responsible to the Owner for the acts or omissions of his subcontractors, and of anyone employed directly, or indirectly, by him or them and this contract obligation shall be in addition to the liability imposed by law upon the Contractor.
- C. Nothing contained in the contract documents shall create any contractual relationship between any subcontractor and the Owner.
- D. The Contractor agrees to bond every subcontractor (and every subcontractor of a subcontractor) by the terms of the Article III General Provisions and Article II Special Provisions of the Contract, Plans and Specifications, as far as, applicable to his work, unless specifically noted to the contrary in the subcontract approved in writing as adequate by the Owner.
- E. Assignment of Contract: No assignment by the Contractor of any principal construction contract, or any part thereof, or of the funds to be received there under by the Contractor, will be recognized unless such assignment has had the written approval of the Owner and the Surety has been given due notice of such assignment and has furnished written consent thereto. Such written approval by the Owner shall not relieve the Contractor of the obligations incurred by him under the terms of this contract. In addition to the usual recitals in assignment contracts, the following language must be set forth: "It is agreed that the funds to be paid to the assignee under this assignment are subject to a prior lien for services rendered or materials supplied for the performance of the work called for in said contract in favor of all such persons, firms, or corporations rendering such services or supplying such materials."
- F. Other Contracts: The Owner may award other contracts for additional work, at the site of the project (or other locations), and the Contractor shall fully cooperate with such other Contractors and carefully fit his own work to that provided under other contracts as may be directed by the Owner. The Contractor shall not commit or permit any act which will interfere with the performance of work by any other Contractor.

III.5 INSURANCE, INDEMNIFICATION, AND HOLD HARMLESS

- A. Contractor's Insurance: Contractor shall procure and maintain for the duration of the contract, insurance against claims for injuries to persons or damages to property which may arise from or in connection with the performance of the work on the specific project covered by these specifications hereunder by the Contractor, the Contractor's agents, representatives, employees or subcontractors. The cost of such insurance shall be included in Contractor's bid.
- B. Minimum Scope of Insurance Coverage shall be substantially equivalent to:
 - 1. Insurance Services Office form number GL 0002) covering Comprehensive General Liability; and Insurance Services Office form number GL 0404 covering

Revised 07/2019

Broad Form Comprehensive General Liability; or Insurance Services Office form number CG 0001 covering Commercial General Liability; and

2. Insurance Services Office Business Auto form number CA 0001 covering Automobile Liability, Code 1 "any auto"; and
3. Workers' Compensation and Employers' Liability Insurance as required by the Labor Code of the State of Nebraska.

C. Minimum Limits of Insurance - Contractor shall maintain limits no less than:

1. a. Commercial General Liability: \$1,000,000 combined single limit for bodily injury, personal injury and property damage.
2. b. Automobile Liability: \$1,000,000 combined single limits and property damage.
3. d. Workers' Compensation and Employers' Liability; Workers' Compensation and Employers' Liability Limits as required by the Labor Code of the State of Nebraska.

D. Use of Bond Requirements

Depending upon the project size and project type, the City may require one or more of the following bonds:

- Bid bond
- Performance bond
- Labor and materials bond
- Maintenance bond
- Dishonesty bond

E. Excess Umbrella Liability Insurance

The Contractor shall procure and shall maintain, during the life of this contract, an Excess Umbrella Liability policy of not less than \$1,000,000 per occurrence in excess of the basic policies required in III.C.1, III.C.2, and III.C.3. Such coverage shall be at least as broad as the primary coverage required in III.C.1, III.C.2 and III.C.3.

F. Deductibles and Self-Insured Retentions

Any deductibles or self-insured retentions must be declared to and approved by the City. If any deductibles exceed \$5,000, or any self-insured retentions exceed \$10,000, either: the insurer shall reduce or eliminate such deductibles or self-insured retentions as respects the City, its officials and employees; or the Contractor shall procure a bond guaranteeing payment of losses and related investigation, claim administration and defense expenses.

G. Other Insurance Provisions

The policies are to contain, or be endorsed to contain, the following provisions:

1. General Liability and Automobile Liability:

- a. The City, its officials, and employees are to be covered as additional insurers as respects to; liability arising out of activities performed by or on behalf of the Contractor; products and completed operations of the Contractor; premises owned, leased or used by the Contractor; or automobiles owned, leased, hired, or borrowed by the Contractor. The coverage shall contain no special limitations on the scope of protection afforded to the City, its officials, or employees.
- b. The Contractor's insurance coverage shall be primary insurance as respects the City, its officials and employees. Any coverage program, insurance or self-insurance, maintained by the City, its officials or employees shall be excess of Contractor's insurance and shall not contribute with it.
- c. Any failure to comply with any reporting provisions of the policies shall not affect coverage provided to the City, its officials or employees.
- d. Coverage shall state that Contractor's insurance shall apply separately to each insured against whom claim is made or suit is brought, except with respect to the limits of the insurer's liability.
- e. If insurance provided is written under the Insurance Services Office form number CG 0001 the coverage shall be endorsed to provide for separate limits for the specific project covered by these specifications.

2. Insurer Termination Provisions:

For each insurance policy required by this contract, the contractor and/or its agent shall arrange for the following provisions pertaining to insurer termination of the policy:

- a. Mid-term cancellation by the insurer for reasons other than non-payment – not less than 30 days' notice to the City;
- b. Mid-term cancellation by the insurer for non-payment – not less than 15 days notice to the City;
- c. Mid-term reduction of coverage to the extent that it no longer is in conformity with contract requirement not less than 30 days notice to the City;
- d. Non-renewal by the insurer – not less than 30 days notice to the City.

Evidence of these provisions shall be provided by the contractor, preferably through an endorsement stating that the City shall be notified of insurance policy termination by the insurer in conformity with the timeframes outlined above. In the

Revised 07/2019

event of the unavailability of an endorsement containing the aforementioned provisions, the City will accept certificate(s) of insurance stating that termination provisions of each policy shall be in conformity with the timeframes above. Endorsement and/or certificates shall stipulate that notices shall be sent by certified mail, return receipt requested.

In the event that neither an endorsement or insurance certificate contain the aforementioned provisions, and City will consider notification of termination by the contractor within two business days after it receives notification from the insurance company of actual or proposed termination of an insurance policy required by the contract. However, the contractor must:

1. notify the City prior to the beginning of the contract period of the unwillingness of the insurer to provide an endorsement or certificate with notification provisions to the City as outlined above; and
2. secure authorization from the City to use this approach.

In the event the contractor elects to terminate coverage mid-term, it shall be the contractor's responsibility to notify the City of the cancellation at least 30 days before the cancellation goes into effect.

Confirmation of any mailed notices of termination by the insurer and/or by the Contractor shall be evidenced by return receipts of registered or certified mail.

On all renewal or replacement policies it shall be the Contractor's responsibility to provide evidence of these policies at least 15 days prior to the inception date of these policies.

H. Acceptability of Insurers

Insurance is to be placed with insurers with a Bests' rating of no less than A-:VIII authorized to do business in the State of Nebraska.

I. Verification of Coverage

Contractor shall furnish the City with certificates of insurance. The certificates for each insurance policy are to be signed by a person authorized by that insurer to bind coverage on its behalf. The certificates are to be received and approved by the City before work commences. The certificates of insurance to be supplied are the most current standard ACORD form, or a substantially equivalent form, and the supplemental endorsement form supplied by the City of Norfolk.

J. Work Stopped Due to Lack of Insurance

All work covered by these specifications shall cease immediately when the insurance required of the Contractor is no longer in force.

K. Indemnification and Hold Harmless

The Contractor shall indemnify and hold harmless the City of Norfolk, Nebraska from and against all losses, claims, damages, and expenses, including attorney's fees, arising out of or resulting from the performance of the contract that results in bodily injury, sickness, disease, death, or injury to or destruction of tangible property, including the loss of use resulting and is caused in whole or in part by the Contractor; any subcontractor; or anyone directly or indirectly employed by either; or anyone for whose acts they may be liable.

L. Defense

The Contractor shall defend any suit that may be brought against the Contractor or Subcontractor, or their employees, agents, or vendors, or the Owner on account of damage inflicted by the Contractor's or Subcontractor's operations, and the Contractor's or Subcontractor's employees, agents, or vendors actions, and shall pay any judgments, interest, and expenses associated with such damage.

M. Assumption of Risk All responsibility for maintenance of property insurance on the work (including but not limited to Builders Risk, Installation Floater, and Building Ordinance Coverage) remains solely with the Contractor. Such responsibility shall remain with the Contractor until such time as the work is complete and accepted in writing by the Owner. It is a condition of the Contract that the Owner and Engineer and all Contractors, Subcontractors and Sub subcontractors waive all rights of recovery against each other for damages caused by fire or other perils to the extent covered by any valid and collectible insurance, and further, that any policy not including the standard waiver of subrogation clause be so endorsed as to comply with this paragraph. In the event of Owner's occupancy of any of the project as permitted under Article titled "Right of Occupancy" or other provisions of the Contract Documents, the Contractor shall have the Builders Risk policy on the project endorsed permitting such occupancy and such endorsement shall not be unreasonably withheld.

III.6 PLANS AND SPECIFICATIONS

A. Plans and Specifications:

a. All work shall be executed in strict conformity with the plans and specifications, and the Contractor shall do no work without prior drawings and instructions.

b. The Engineer will furnish the Contractor, free of charge, three copies of drawings and specifications.

c. Figured dimensions on the plans shall be taken as correct, but shall be checked by the Contractor before starting construction.

d. Any errors, omissions, or discrepancies shall be brought to the attention of the Engineer and his decision thereon shall be final.

Revised 07/2019

e. All notes on the plans shall be followed.

f. Correction of errors, or omissions on the drawings or specifications may be made by the Engineer when such correction is necessary for the proper execution of the work.

B. Intent of Contract Documents:

a. The sections of the contract documents and the contract plans are complimentary, and what is called for by any one shall be as binding as if called for by all. The intention of the contract documents is to include in the contract price the cost of all labor and materials, water, fuel, tools, plant, equipment, light, insurance, bonds, transportation and all other expense as may be necessary for the proper execution of the work.

b. Any work shown on the plans and not covered in the specifications, or included in the specifications and not shown on the plans, shall be executed by the Contractor as though shown both on the plans and specifications. If the plans and specifications should be contradictory in any part, the specifications shall govern.

c. Any minor items not specifically called for in the plans and specifications, but which are necessary to complete the work ready for use in accordance with the requirements of good practice, as determined by the Engineer, shall be included as a part of the Contractor's bid price and furnished at no additional cost to the Owner.

d. In interpreting the contract documents, words describing materials or work which have a well known technical or trade meaning, unless otherwise specifically defined in the contract documents, shall be construed in accordance with such well known meaning recognized by architects, engineers, and the trade.

C. Interpretation of Proposed Contract Documents: If any person contemplating submitting a bid for this contract is in doubt to the true meaning of any part of the plans, specifications, or other proposed contract documents, he may submit to the Engineer a written request for an interpretation thereof. The person submitting the request will be responsible for its prompt delivery. Any interpretation of the proposed documents will be made only by addendum duly issued or delivered to each person receiving a set of such documents. The Owner will not be responsible for any other explanations or interpretations of the proposed documents.

D. Standard Manufacturer: Whenever the terms "standard", "recognized", or "reputable" manufacturer are used, they shall be construed as meaning manufacturers who have been engaged in the business of fabricating materials, equipment, or supplies of the nature called for by the specifications for a reasonable period of time prior to the date set for opening of bids, and who can demonstrate to the satisfaction of the Owner, that said manufacturer has successfully installed equipment, materials, or supplies of the type proposed to be furnished in a least three (3) instances, and that the performance of such materials, equipment, or supplies has been satisfactory. Manufacturers who have been engaged in the business of

manufacturing said materials, equipment, or supplies for a period of over twelve months prior to the date fixed for opening bids shall, prima facie, be deemed to have been engaged in such business for a reasonable length of time.

E. "Or Equal" Clause: Whenever in any section of the contract documents, plans or specifications, any article, material, or equipment is defined by the term "or equal" the specific article, material, or equipment mentioned shall be understood as indicating the type, function, minimum standard of design, efficiency, and quality desired.

F. Materials and Workmanship:

a. Unless otherwise stipulated in the specifications, all workmanship, equipment, materials and articles incorporated in the work covered by this contract are to be new and of the best grade of their respective kinds for the purpose, and shall be guaranteed by the Contractor and the Surety for a period of one (1) year. The Contractor shall furnish to the Engineer for his approval, the name of the manufacturer of machinery mechanical and other equipment, which he contemplates installing, together with their performance capacities and other pertinent information.

b. When required by the specifications, or when called for by the Engineer, the Contractor shall furnish for approval full information concerning the materials or articles which he contemplates incorporating in the work. Samples of materials shall be submitted for approval when so directed. Machinery, equipment, materials and articles installed or used without such approval shall be at the risk of subsequent rejection. All materials and workmanship shall be guaranteed by the Contractor and the Surety for a period of one year from date of final estimate.

c. No materials of any kind shall be installed in the project until it has been inspected and accepted by the Engineer. All materials rejected shall be immediately removed from the site of the work and not again offered for inspection. Any materials or workmanship found at the time to be defective shall be remedied at once regardless of previous inspections.

d. At any time during the course of construction of this project when in the opinion of the Engineer provisions of the plans, specifications, or contract provisions are being violated by the Contractor or his employees, the Engineer shall have the right and authority to order all construction to cease or material to be removed until arrangements satisfactory to the Engineer are made by the Contractor for resumption of the work in compliance with the provisions of the contract.

e. Where required for construction, the Contractor shall remove and replace as required, fences, street signs, mail boxes, culverts, and other miscellaneous items. The replacement shall be with removed materials or new materials of like character. Fences shall be restored at least equal to or better than the original condition. The Contractor shall be responsible for maintaining temporary fence when the fence is removed.

Revised 07/2019

Miscellaneous removals and replacements will not be measured for payment, but shall be considered subsidiary to the pipe installation.

G. Shop Drawings:

a. The Contractor as soon as possible after approval of the source and the purpose of items of materials and equipment shall submit to the Engineer all shop or setting drawings and schedule required for the work, including those pertaining to structural and reinforcing steel. The Contractor shall make any corrections in the drawings required by the Engineer, and resubmit same without delay.

b. It shall be the responsibility of the Contractor to determine the correctness of all dimensions and minor details of such equipment, and materials so that when incorporated in the work correct operations will result.

H. As Built Records:

The Contractor shall maintain a set of Plans on the project to record all field changes and measurements recorded as installations progress.

A good quality color photo shall be provided for each fitting installation. It shall be taken close enough to show a clear picture of the fitting(s). More than one photo may be needed in some cases. Each photo shall be well identified on the back with location and type of fitting(s).

The field corrected Plans and installation photos shall be provided to the Engineer prior to approval of final payment of the Contractor.

The Contractor shall notify the Engineer prior to covering any buried items, such as valves, fittings, or other appurtenances, in order for the Engineer to verify the location and elevation of such items.

III.7 ENGINEERING SUPERVISION

A. Authority of Engineer:

a. The Engineer in this contract is acting as an agent for the Owner to protect the interests of the Owner and to insure that the Contractor's work is done in full compliance with the terms of the contract. He has the authority to stop the work whenever necessary to insure the proper execution of the contract.

b. The Engineer shall decide all questions which may arise as to the fulfillment of the contract on the part of the Contractor and his decision thereon shall be final and conclusive subject to the approval of the Mayor and City Council.

c. No resident engineer or inspector or representative appointed by the Owner shall have any power to waive any of the conditions or obligations of this contract without the express consent and approval of the Owner.

B. Testing of Materials:

a. All laboratory tests shall be made by an approved testing laboratory, except the Engineer may make any tests in his own laboratory. If the Contractor is unwilling to accept the results of tests performed in the Engineer's laboratory, he shall pay all of the costs of having the testing or retesting done in a Testing Laboratory approved by the Engineer.

b. The specific test requirements are set forth in the section of these specifications which describe the materials to be tested or in the Special Provisions. The Contractor shall furnish the materials to be tested and shall pay transportation charges on any samples required to be submitted to the laboratory and the cost of the cylinder molds.

c. The Engineer will furnish the Contractor a copy of the testing reports as they become available.

d. When additional testing is required to determine whether or not the work meets the specifications at specific locations, the Contractor shall pay all the costs of tests that indicate noncompliance with the specifications.

e. Where manufacturer's certified test reports are required, these reports must be submitted before the material is approved for use.

f. Testing of the sewer and water pipe and force mains for performance will not be measured for payment, but shall be considered as subsidiary to the installation of the pipe for which payment is made, unless directed otherwise in the Special Provisions.

C. Staking Work: The Engineer will set control stakes for general layout and all necessary grade stakes for construction work. The Engineering Division shall be given 72 hours before construction begins to allow time for staking. The protection and care of such stakes shall be the responsibility of the Contractor. The Contractor may, at the discretion of the Engineer, be required to pay the cost of replacing stakes which are lost or destroyed. The detail layout of structures and staking of individual items shall be done by the Contractor subject to check by the Engineer as a compliance with the contract plans and specifications. In any case, the Contractor shall be responsible for the correctness and accuracy of the detail layout of finished structures.

D. Inspection:

a. The Engineer and his authorized representative shall at all times have access to the work wherever it is in preparation or progress and the Contractor shall provide proper facilities for such access and for inspection.

b. The Engineer shall have the right to reject materials and workmanship which are defective, or require their correction. Rejected workmanship shall be satisfactorily corrected and rejected materials shall be removed from the premises without charge to the Owner. If the Contractor does not correct such condemned work and remove rejected materials within a reasonable time fixed by written notice, the Owner may remove them and charge the expense to the Contractor.

c. Should it be considered necessary or advisable by the Engineer at any time before final acceptance of the final work to make an examination of work already completed, by removing or tearing out same, the Contractor shall on request promptly furnish all necessary facilities, labor and materials. If such work is found to be defective in any materials respect due to fault of the Contractor or his subcontractor he shall defray reconstruction. If, however, such work is found to meet the requirements of the contract, the actual cost of labor and material necessarily involved in the examination and replacement, plus 15 percent, will be allowed the Contractor.

d. All materials to be incorporated in the work all labor performed, all tools, appliances, and methods used shall be subject to the inspection and approval or rejection of the Engineer.

e. If the Engineer shall point out to the Contractor, his foreman or agent, any neglect or disregard of the contract provisions such neglect or disregard shall be remedied and further defective work be at once discontinued.

f. The Contractor shall execute the work only in the presence of the Engineer or authorized inspectors, unless provision has been made for the work to proceed without complete engineering supervision or inspection. The presence of the Engineer or inspector shall in no way relieve the Contractor of the responsibility of this contract, or be any warrant for the furnishing of bad material or poor workmanship.

g. The inspection of the work by the Engineer is intended to aid the Contractor in applying labor, materials and workmanship in compliance with the contract provisions. Such inspection however shall not operate to release the Contractor from any of his contract obligations.

III.8 CONTRACTOR'S WORKING CONDITIONS

A. Superintendence and Labor:

- a. The Contractor shall give his personal superintendence to the work or have at the site of the work at all times a competent foreman, superintendent, or other representative satisfactory to the Owner and the Engineer and having authority to act for the Contractor.
- b. The Contractor shall employ none but competent and skilled workmen and foreman in the conduct of work on this contract. The Engineer shall have the authority to order the removal from the work of any Contractor's employee who refuses or neglects to observe any of the provisions of these plans or specifications, or who is incompetent, unfaithful, abusive, threatening, or disorderly in his conduct, and any such person shall not again be employed on this project without the permission of the Engineer.

B. Use of Job Site and Private Land:

- a. The Contractor shall confine his equipment, apparatus, the storage of materials and operations of his workmen to limits indicated by law, ordinances, permits or directions of the Owner and shall not encumber the premises with his materials.
- b. The Contractor shall not load or permit any part of the structure to be loaded with a weight that will endanger its safety. The Contractor shall enforce the Owner or Owner's authorized representative instructions regarding signs, advertisements, fires and smoke.
- c. The Contractor shall not use any vacant lot, private land, or City owned land outside of the project site as a plant site, depository for materials, or as a spoil site without the written authorization of the owner (or his agent of the land).

C. Protection of Work:

- a. The Contractor shall continuously maintain adequate protection of all his work from damage and shall protect the Owner's and adjacent property from injury arising in connection with his contract.
- b. The Contractor will be responsible for any and all damages to property, public or private, that may be caused by his operations in the performance of this contract, and the Contractor shall defend any suit that may be brought against himself or the Owner on account of damage inflicted by his operations, and shall pay any judgments awarded to cover such damage.

D. Accident Prevention:

- a. Precaution shall be exercised at all times for the protection of persons (including employees) and property. The safety provisions of applicable laws, building and

Revised 07/2019

construction codes shall be observed. The Contractor shall be solely responsible for conducting his work in compliance with the "Occupational Safety and Health Act of 1970", and the requirements of the Nebraska State Department of Labor and Safety. The Contractor shall put up and maintain such barriers as will effectively prevent accidents. During the night hours, he shall put up and maintain sufficient lights to warn and safeguard the public against accidents. The Contractor in executing the work on this project shall not unnecessarily impede or interfere with traffic on public highways or streets. Any questions as to what constitutes unnecessary interference with traffic or a hazard to traffic shall be settled by the Engineer. The Contractor shall be solely responsible for the design, construction, inspection and maintenance of all of the shoring, bracing, dewatering, and warning signs and barricades.

b. The Contractor shall, prior to any construction, contact all utility companies to determine the location of all underground utilities including, but not limited to, telephone, Cable TV, electric, gas, water, and sewer. The Contractor shall take all necessary precautions to avoid damaging any existing utilities found. In the event that an existing utility is damaged, the Contractor shall repair the damaged utility at no additional cost to the Owner.

c. The Contractor shall confer with and keep Police and Fire Division of the Owner fully informed as to streets or alleys which are to be closed to traffic for construction purposes.

d. The Contractor shall supply the Engineer with names of at least two individuals, complete with phone number, that can be contacted on a 24 hour a day basis to add, repair, and/or replace damaged, broken, stolen, or insufficient barricades.

E. Sanitary Conveniences: The Contractor shall provide and maintain on the construction work at all times, suitable sanitary facilities for use of those employed on this contract without committing any public nuisances. Pit type toilets shall be of proper design and fly tight. All toilet facilities shall be subject to the approval of the State Health Department.

F. Cost of Services:

a. The Contractor will be required to pay for city water at the standard rate outlined in City Code.

b. The cost of all power, lighting, and heating required during construction shall be paid by the Contractor and its cost merged in the contract price.

G. Work in Bad Weather: No construction work shall be done during stormy, freezing or inclement weather, except such as can be done satisfactorily, and in a manner to secure first class construction throughout, and then only subject to permission of the Engineer.

H. Cleaning up and Final Inspection:

- a. The Contractor shall at all times keep the site of the work free from accumulations of waste materials or rubbish caused by his employees or work, and at the completion of the work he shall remove all his rubbish from and about the work, and all his tools, equipment, scaffolding, and surplus materials and shall leave his work clean and ready for use. In case of dispute, the Owner may remove the rubbish and surplus materials and charge the cost to the Contractor.
- b. The Contractor shall, at his own expense, dispose of all waste and construction debris at a disposal area off the site, which is approved by the governmental authorities having jurisdiction.
- c. No dirt or sediment is allowed to leave the site or enter into stormwater runoff. No construction activities occur in muddy areas that may result in tracking dirt and/or mud off the construction site. If such situations cannot be avoided, the Contractor will be responsible for immediately cleaning all dirt from surrounding pavement and preventing it from entering any stormwater runoff. The Contractor will be responsible for maintaining sediment control for all runoff from the construction area.
- d. All sewers, conduits, pipes and appurtenances, and all tanks, pump wells, chamber buildings, and other structures shall be kept clean during construction, and as the work or any part thereof approaches completion, the Contractor shall systematically and thoroughly clean and make any needed repairs to them. He shall furnish at his own expense, suitable tools and labor for removing all water and cleaning out all dirt, mortar and foreign substances. Any undue leakage of water into the structure such as to make the work, in the opinion of the Engineer, fall short of first class work, shall be promptly corrected by the Contractor at his own expense. Cleaning and repairs shall be arranged, so far as practicable, to be completed upon finishing the construction work. Notice to begin the final cleaning, and repairing if such is needed, will be given by the Engineer, who at the same time will make his final inspection of the work. The Engineer will not approve the final estimate of any portion of the work until after the final inspection is made and the work found satisfactory.

I. Cutting and Patching:

- a. The Contractor shall do all cutting, fitting or patching of his work that may be required to make its several parts fit together or to receive the work of other contractors shown upon, or reasonably implied by the plans and specifications for the completed project.
- b. Any cost caused by defective or ill-timed work shall be borne by the party responsible therefore.
- c. The Contractor shall not endanger any work by cutting, digging or otherwise, and shall not cut or alter the work of any other Contractor without the consent of the Engineer.

- J. Final Tests: After completion of the work the Contractor shall make any and all tests required by municipal or state regulations, and where so provided in said regulations shall furnish the Owner with certificates of inspection by the municipal or state regulation bodies. The Contractor shall also make all tests required by the National Board of Fire Underwriters for the purpose of determining insurance rates or other protection of the Owner or the public.
- K. Correction of Work after Final Payment: Neither the final payment, nor any provision in the contract documents, shall relieve the Contractor of the responsibility for negligence or faulty materials or workmanship within the extent and period provided by law.
- L. Termination for Breach: In the event that any of the provisions of this contract are violated by the Contractor or by any of his subcontractors, the Owner may serve written notice upon the Contractor and the Surety of its intention to terminate the Contract, and unless within ten (10) days after the serving of such notice upon the Contractor, such violation shall cease and satisfactory arrangements for corrections be made, the contract shall, upon the expiration of said ten (10) days, cease and terminate. The Owner shall not serve such written notice without first having secured from the Engineer a written opinion that a violation of contract has been committed. In the event of any such termination, the Owner shall immediately serve notice thereof upon Surety and the Contractor, and the Surety, shall have the right to take over and perform the contract, provided, however, that if the Surety does not commence performance thereof within thirty (30) days from the date of the mailing to assure Surety of notice of termination, the Owner may take over the work and prosecute the same to completion for the account and at the expense of the Contractor, and the Contractor and his Surety shall be liable to the Owner for any excess cost thereby occasioned the Owner.
- M. Final Acceptance of the Work:
- a. The Contract shall be deemed as having been finally accepted by the Owner and its governing body by certification of completion issued by the City Engineer and formal action by the Mayor and Council accepting the City Engineer's certification.
 - b. Use of part of the improvement by the Owner before completion of the entire project is not to be construed by the Contractor as an acceptance by the Owner of that part so used.
- N. Commencement and Completion of Work: The Contractor shall commence work within ten (10) calendar days of the date of the execution of the contract (unless otherwise stated in the Proposal Form) and complete the contract by the completion date set forth in the Proposal.
- O. Liquidated Damages: In the event that the Contract has not been completed within the specified time (including any approved time extensions) the costs of engineering services beyond said time shall be paid by the Contractor, as liquidated damages. No other liquidated damages will be charged for non-completion within the specified time unless specifically stated in the Special Provisions or on the Bid Proposal.

- P. Barricades, Traffic Control & Closures: When work is in progress on or adjacent to streets or highway, the Contractor shall erect warning signs according to the Manual on Uniform Traffic Control Devices. The Contractor shall submit a traffic control plan prior to construction.

III.9 MEASUREMENT AND PAYMENT

A. Measurement of Work:

- a. If the proposal for the work under this contract is on a unit price basis, the actual number of units of each item of work to be constructed may be more or less than the corresponding number given in the proposal sheet or plan, but no variation will be made in the contract unit prices on that account.
- b. Water mains and services will be measured along the center line of the pipe through fittings and valves. This lineal feet measured will be paid for at the bid price per lineal foot for water main complete in place.
- c. Sewer mains and services will be measured along the center line of the pipe through all fittings and manholes. The lineal feet measured will be paid for at the bid price per lineal feet of sewer line complete in place.
- d. Concrete pavement will be measured along the center line of the street. The width used in calculating the final quantities shall be the standard width for that street. Foundation Course is subsidiary to the price per square yard for Build 6" Concrete with integral curb and gutter. Measurement shall not exclude surface openings for manholes, catch basins or valve boxes.
- e. Concrete Curb will be measured on the face of the curb from end to end. Openings in the curb for drives shall be included in the measurement.
- f. Concrete curb and gutter will be measured on the face of the curb as for concrete curb.
- g. Extra grading shall be calculated using the original cross-sections or profile and the final paving grade. This item includes only the excavation required above the new final street cross-section. All other grading is subsidiary to the pavement bid price.
- h. Manholes measurement shall be by unit each, or by the unit vertical foot as measured from the invert of the sewer to the bottom of the cast iron ring, depending upon the units used on the bid proposal sheet. This payment shall constitute full compensation for all labor and material to completely install the manhole, except ring and cover.
- i. Cast Iron Ring and Cover measurements shall be by unit each and payment shall be the unit bid price for the cover installed.

j. Wye, Branches, Tees and Plugs measurement shall be by unit each, and payment at the unit bid price.

k. Measurement and payment for cleanouts shall be by unit each and payment shall be at the unit bid price. Such payments shall constitute the material and labor required to completely install the cleanout as shown on the plans and drawings this includes the cost for the pipe to the surface and the ring and cover.

l. No separate payment shall be made for manhole stub outs, except that the pipe required to make these "stub outs" shall be paid for as sewer main.

m. Other Units complete in place and ready for use will be counted and paid for as designated in the Proposal or Special Provisions.

n. Extra Work shall be measured in the units commonly used for the type of work, or as indicated by the method of payment. Payments for extra work shall be determined as described in these General Conditions.

B. Payments:

a. No later than two weeks preceding the council meeting for payment, and at the completion of the work under contract the Contractor and/or the Engineer shall prepare and submit a detailed estimate of the work performed during the period, such estimate to be used after approval as a basis for periodical and final payments.

b. The Owner will make partial payment to the Contractor on the basis of a duly certified and approved estimate of the work performed by the Contractor during the preceding calendar month. The Owner at its discretion may include in such monthly estimates, payment for materials that will eventually be incorporated in the project, provided that such material is suitably stored on the site of the project at the time of submission of the estimate for payment. Payment for materials on hand, but not in place, shall be based on the Contractor's cost of such materials stored at the job site, as evidenced by material bills and freight bills. No additional allowances will be made for handling or drayage by the Contractor's forces, nor for overhead, insurance profit or other incidental costs. The Contractor shall, if required by the Engineer, present certified copies of receipted bills, and freight bills for such materials. Such material when so paid for by the Owner will become the property of the Owner, and in case of default on the part of the Contractor, the Owner may use or cause to be used by others these materials in construction of the project.

c. Prior to Substantial Completion, progress payments will be made in an amount equal to the percentage indicated below but, in each case, less the aggregate of payments previously made and less such amounts as Engineer may determine or Owner may withhold, including but not limited to liquidated damages.

Revised 07/2019

1. 90 percent of Work completed (with the balance being retainage). If the Work has been 50 percent completed as determined by Engineer, and if the character and progress of the Work have been satisfactory to Owner and Engineer, then as long as the character and progress of the Work remain satisfactory to Owner and Engineer, there will be no additional retainage; and
2. 90 percent of cost of materials and equipment not incorporated in the Work (with the balance being retainage).

d. A certified statement in triplicate of the estimate will then be submitted by the Engineer to the Owner for approval. When approved, one copy will be returned to the Contractor and two copies will be retained by the Owner.

e. Final payment of the percentages retained by the Owner on the monthly periodical estimates, and on the final estimates, will be paid to the Contractor not more than thirty (30) days after final acceptance by the Owner of the work on this contract, except as stated in the following article. Payments may be made by registered warrants bearing interest.

C. Owner's Right to Withhold Certain Amounts and Make Applications Thereof: The Owner may withhold, in addition to retained percentages, from payment to the Contractor, such an amount or amounts as may be necessary to cover:

- a. Payments that may be earned or due for just claims for labor or materials furnished in and about the work.
- b. For defective work not remedied.
- c. For failure of the Contractor to make proper payments to his subcontractors.
- d. Reasonable doubt that the contract can be completed for the balance then unpaid.
- e. Evidence of damage to another contractor.
- f. Excess cost of field engineering and inspection.

D. The Owner shall disburse and have the right to act as agent for the Contractor in disbursing such funds as have been withheld pursuant to this paragraph to the party or parties who are entitled to payment there from. The Owner will render to the Contractor for a proper accounting of all such funds disbursed in behalf of the Contractor.

E. The Owner also reserves the right even after full completion and acceptance of the work to refuse payment of the final percentage due the Contractor, until it is satisfied that all subcontractors, material supplies, and employees of the Contractor have been paid in full.

- F. Deduction for Uncorrected Work: If the Owner deems it expedient to accept work injured or not done in accordance with the contract, an equitable adjustment will be made with a proper deduction from the contract price for unsatisfactory work.
- G. Change Order and Extras: The Owner, upon proper action by its governing body, may without invalidating the Contract, authorize the Engineer to direct that changes be made in the work to be performed or the materials to be furnished pursuant to the provisions of this contract. All such work shall be executed under the conditions of the original contract.
- H. Adjustments, if any, in the amounts to be paid to the Contractor by reasoning of any such change shall be determined by one or more of the following methods:
- a. By unit prices contained in the Contractor's original bid and incorporated in this construction contract, or subsequently agreed upon.
 - b. By an acceptable lump sum proposal from the Contractor.
 - c. On a cost plus limited basis not to exceed a specified limit (defined as the cost of labor, materials, and insurance plus a specified percentage of the cost of such labor, materials and insurance; provided the specified percentage does not exceed fifteen percent (15%) of the aggregate cost of the labor, materials, and insurance and shall in no event exceed a specified limit).
 - d. No claim for an addition to the contract sum shall be valid unless authorized as aforesaid.
 - e. In cases where a lump sum proposal is submitted by the Contractor in excess of \$500.00 (Five Hundred Dollars) and the Engineer considers the proposal so submitted is excessive or unreasonable for the changes or added work contemplated, the Owner reserves the right to request a proposal for the same changed items from other Contractors. If a proposal for such added work is obtained from other Contractors at a lesser amount, the Owner reserves the right to make an award for such work to another Contractor unless the Contractor on this contract agrees to do the added or changed work for the price named by the other Contractor.
 - f. It shall be expressly understood and hereby agreed to by the Contractor that no claim for extra work will be recognized by the Owner unless same has been ordered in writing by the Owner, or the Engineer, and unless claim for such added work has been filed by the Contractor within five (5) days after the end of the calendar month in which such alleged extra work was performed.
 - g. Inspectors and resident engineers are not authorized to act for the Owner in giving orders for the Owner for extra or additional work either in writing or verbally.

I. Nebraska Sales Tax: The bid price and the total contract bid amount shall include all applicable Nebraska Sales Tax. The City is required to pay the Nebraska Sales Tax on Water contracts, therefore, the bidder shall include the amount of the tax in his bid.

J. Utilities:

a. The Owner shall furnish all legal plats describing the construction area, if required, and the Contractor shall immediately upon entering the project site for the purpose of beginning work, locate reference points and survey monuments and take such actions as are necessary to prevent their destruction. The Contractor shall verify existing conditions shown on the drawings before constructing any work, and shall correct without additional change to the Owner any defects in the work resulting from his failure to perform this verification.

b. The Contractor shall determine the actual location of all existing utilities prior to starting any work that may cause damage to such utilities.

c. The Contractor shall indemnify and hold harmless the Owner and the Engineer, and their agents and employees, from and against all claims, damages, losses and expenses including attorney's fees arising as a result of damage to existing utilities caused in whole or in part by the Contractor or any subcontractor, anyone directly or indirectly employed by any of them or anyone for whose acts may be liable, regardless of whether or not it is caused in part by a party indemnified hereunder.

d. Any information concerning underground utilities shown on the drawings is intended to be merely an aid to the Contractor. The accuracy of information furnished with respect to underground utilities is not guaranteed, and the Contractor must independently verify any such information.

e. The Contractor shall notify all utility companies who have installations in the area where the work is to be performed and solicit their aid in locating utilities including, but not limited to, sewer, water, cable TV, gas or other fuel, electrical and telephone installations. All utilities encountered must be kept in operation by the Contractor and must be protected and/or repaired at his own expense.

f. The Contractor shall inform the Engineer if utility installations are encountered that must be relocated prior to completing the work. If the Engineer determines that such utilities must be moved, the Owner shall bear the cost of moving such utilities.

g. If in the course of construction survey monuments are destroyed, the Contractor shall be held responsible for replacement. If replacement is necessary, the Contractor shall, prior to final payment, obtain the services of a licensed surveyor who shall re-establish all such monuments with reference at no cost to the Owner.

h. The Contractor shall indemnify and hold harmless the Owner and Engineer from liability of any kind arising from any use, trespass, or damage occasioned, in whole or in part, by his operation on premises of a third person.

K. Electrical Lines or Other Utilities: It shall be the Contractor's sole and exclusive responsibility:

a. to provide personnel capable of working adjacent to energized electrical lines or other utilities;

b. to provide adequate, safe and properly maintained equipment;

c. to conduct all of his work in accordance with the safety rules and regulations prescribed by the National Electrical Code, National Electric Safety Code, H30, and Safety Rules for Installation and Maintenance of Electrical Supply and Communication Lines Handbook 81, Occupational Safety and Health Act of 1970, as well as other safety codes in effect at the site of construction and as specified elsewhere herein, or as are generally applicable to the type of work being performed; and

d. to continuously supervise and inspect the work being performed to assure that the requirements of (a), (b), and (c) above are complied with and nothing in these Contract Documents shall be held to mean that any such responsibility is the obligation of the Owner or the Engineer.

L. Soil Borings and Subsurface Data: The Contractor may examine the logs of boring, cores and other subsurface data, if available, by making a request to the Owner and to the Engineer. Such data, if available, is offered solely for the purpose of placing at the Contractor's disposal, available information. Such information is not to be construed as part of the Contract Documents. The Contractor must interpret such information according to his own judgment and must not rely upon such information as an accurate description of the subsurface conditions that may arise. The Contractor assumes all risks connected with the subsurface conditions actually encountered by him in performing more or less work than he originally estimated. Any soil investigations made or to be made by a Testing Laboratory will be considered to have been made by the Owner as the Testing Laboratory's client. Any partial or complete reproduction of soil borings or other soil data issued with these Contract Documents for informational purposes shall not be considered as part of the Contract Documents for the construction of the project.

M. Coordination with Other Contractors: The Contractor shall coordinate his work with that of any other Contractor working in the same area. Should damages occur as a result of the Contractor not so coordinating his work with others, the Contractor will hold the City of Norfolk harmless from any expense due to these damages.

N. Fire Protection: Adequate provisions shall be made throughout the construction of this project to insure that fire fighting equipment can reach each property within the general area.

Revised 07/2019

- O. Trees and Shrubs: Trees and shrubs shall not be removed unless provided for in the Special Provisions. Removal of trees and shrubs shall be subsidiary to pavement or pipe installations unless payment is provided for as a bid item on the proposal.
- P. Pay Items: All items of work not specifically set out in the proposal shall be considered subsidiary to other pay items and will not be paid for directly.
- Q. Sprinklers: Any damage to lawn sprinklers shall be repaired by the Contractor.
- R. Over Excavation Material: "Over Excavation", which may be saturated with sanitary sewer shall be hauled to City property adjacent to the City's Water Pollution Control Plant. Upon relocation, material is to be spread evenly and seeded. The Contractor shall coordinate with the City for exact location of placing material.

III.10 WORK ELIGIBILITY STATUS VERIFICATION

- A. E-Verify Program: The Contractor is required and hereby agrees to use a federal immigration verification system to determine the work eligibility status of new employees physically performing services within the State of Nebraska. A federal immigration verification system means the electronic verification of the work authorization program authorized by the Illegal Immigration Reform and Immigrant Responsibility Act of 1996, 8 U.S.C. 1324a, known as the E-Verify Program, or an equivalent federal program designated by the United States Department of Homeland Security or other federal agency authorized to verify the work eligibility status of a newly hired employee.
- B. United States Citizenship Attestation Form: In addition contractor's organized as individuals or sole proprietorship's must complete the United States Citizenship Attestation Form, available either on the Department of Administrative Services website at www.das.state.ne.us or from the City of Norfolk. If he/she indicates on such attestation form that he/she is a qualified alien, he/she agrees to provide the US Citizenship and Immigration Services documentation required to verify his/her lawful presence in the United States using the Systematic Alien Verification for Entitlements (SAVE) Program. He/She understands and agrees that lawful presence in the United States is required and he/she may be disqualified or the contract terminated if such lawful presence cannot be verified as required by Neb. Rev. Stat. §4-108.

III.11 TITLE VI NON-DISCRIMINATION PROGRAM

During the performance of this contract, the contractor, for itself, its assignees and successors in interest (hereinafter referred to as the "contractor") agrees as follows:

- (1) Compliance with Regulations: The contractor shall comply with the Regulation relative to nondiscrimination in Federally-assisted programs of the Department of Transportation (hereinafter, "DOT") Title 49, Code of Federal Regulations, Part 21, and the Federal Highway

Administration (hereinafter "FHWA") Title 23, Code of Federal Regulations, Part 200 as they may be amended from time to time, (hereinafter referred to as the Regulations), which are herein incorporated by reference and made a part of this contract.

(2) Non-discrimination: The Contractor, with regard to the work performed by it during the contract, shall not discriminate on the grounds of race, color, or national origin, sex, age, and disability/handicap in the selection and retention of subcontractors, including procurements of materials and leases of equipment. The contractor shall not participate either directly or indirectly in the discrimination prohibited by 49 CFR, section 21.5 of the Regulations, including employment practices when the contract covers a program set forth in Appendix B of the Regulations.

(3) Solicitations for Subcontractors, Including Procurements of Materials and Equipment: In all solicitations either by competitive bidding or negotiation made by the contractor for work to be performed under a subcontract, including procurements of materials or leases of equipment, each potential subcontractor or supplier shall be notified by the contractor of the contractor's obligations under this contract and the Regulations relative to nondiscrimination on the grounds of race, color, or national origin, sex, age, and disability/handicap.

(4) Information and Reports: The contractor shall provide all information and reports required by the Regulations or directives issued pursuant thereto, and shall permit access to its books, records, accounts, other sources of information, and its facilities as may be determined by the (Recipient) or the FHWA to be pertinent to ascertain compliance with such Regulations, orders and instructions. Where any information required of a contractor is in the exclusive possession of another who fails or refuses to furnish this information the contractor shall so certify to the (Recipient), or the FHWA as appropriate, and shall set forth what efforts it has made to obtain the information.

(5) Sanctions for Noncompliance: In the event of the contractor's noncompliance with the nondiscrimination provisions of this contract, the (Recipient) shall impose such contract sanctions as it or the FHWA may determine to be appropriate, including, but not limited to: (a.) withholding of payments to the contractor under the contract until the contractor complies, and/or (b.) cancellation, termination or suspension of the contract, in whole or in part.

(6) Incorporation of Provisions: The contractor shall include the provisions of paragraphs (1) through (6) in every subcontract, including procurements of materials and leases of equipment, unless exempt by the Regulations, or directives issued pursuant thereto.

The contractor shall take such action with respect to any subcontract or procurement as the (Recipient) or the FHWA may direct as a means of enforcing such provisions including sanctions for non-compliance: Provided, however, that, in the event a contractor becomes involved in, or is threatened with, litigation with a subcontractor or supplier as a result of such direction, the contractor may request the (Recipient) to enter into such litigation to protect the interests of the (Recipient), and, in addition, the contractor may request the United States to enter into such litigation to protect the interests of the United States.

Revised 07/2019

III.12 CLEAN UP

The Contractor shall clean up his area of construction debris and shall leave the area of construction in a neat, uncluttered condition, graded to uniform lines and grades. Cleaning up will not be measured for payment, but shall be considered subsidiary to other work for which payment is provided.

The Contractor shall, at his own expense, dispose of all waste and construction debris at a disposal area off the site which is approved by governmental authorities having jurisdiction.

No dirt or sediment is allowed to leave the site or enter into stormwater runoff. If any dirt is tracked off site due to construction, personnel or equipment, the contractor is responsible for cleaning up such dirt immediately. No construction activities shall occur in muddy areas that may result in tracking dirt and/or mud off of the construction site. If such situations cannot be avoided the contractor will be responsible for immediately cleaning all dirt from surrounding pavement and prevent it from entering any stormwater runoff. The contractor will be responsible for maintaining sediment control for all runoff from the construction area.

III.13 SEDIMENT & EROSION CONTROL, AND POLLUTION PREVENTION

The Contractor shall maintain all necessary best management practice(s) (BMP's) to prevent stormwater pollution and sediment and erosion control. The BMP's shall be inspected by the Contractor on a daily basis. These BMP's include but are not limited to the following:

- a) Low and high porosity silt fence around all inlets, boxes, and other stormwater drainage structures as shown on plans. See "Silt Fence Detail" this section. A frame constructed out of 2" x 2" wood boards may be necessary to support the silt fence in high flow areas.
- b) Gutter buddies, curb socks, or the like shall be placed at all inlets upon completion of paving. They shall also be placed at all flumes and inlets that receive stormwater flow from the construction site that are located both inside and outside the limits of construction. See "Inlet Protection Detail" this section.
- c) Low porosity silt fence should be constructed around all dirt/soil stockpiles and any location deemed appropriate by Engineer. All silt fence installed per manufactures recommendations. See "Fabric Silt Fence" detail this section.
- d) A concrete washout pit should be proposed by contractor or require all cement trucks to wash out back at the concrete plant. It is the Contractors responsibility to ensure concrete washout is properly disposed of.
- e) Where necessary, a rock access should be maintained for all construction traffic entering and exiting the site. Geotextile fabric shall be used to keep separation of the rock and the soil below.

Revised 07/2019

- f) All streets should be kept clean of dirt and sediment. Contractor shall immediately clean dirt from streets if trackoff does occur.
- g) Protection should be maintained near all refueling posts, generators, or chemical storage areas.
- h) Erosion Control Mat shall be manufactured by North American Green, Type C125 or approved equal. Seeding shall be applied prior to placement of mat. Installation of erosion control mat to be installed per manufacturer's recommendation.
- i) When necessary the Contractor shall provide a location to keep the SWPPP (Stormwater Pollution Prevention Plan) on site at all times until final stabilization occurs

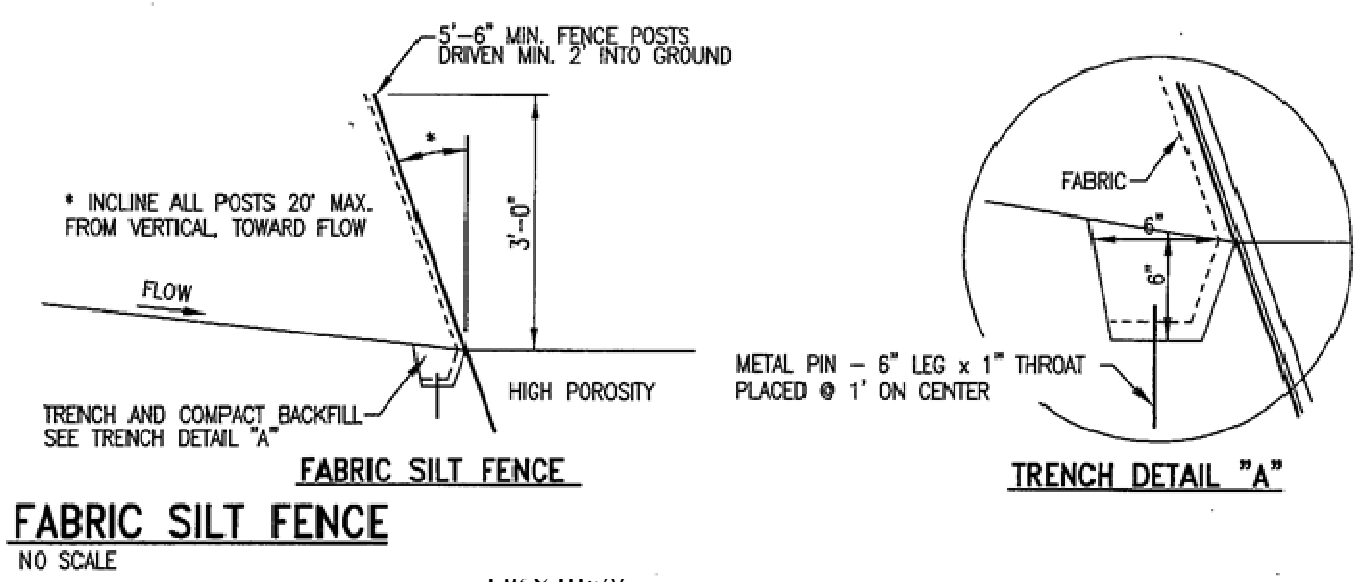
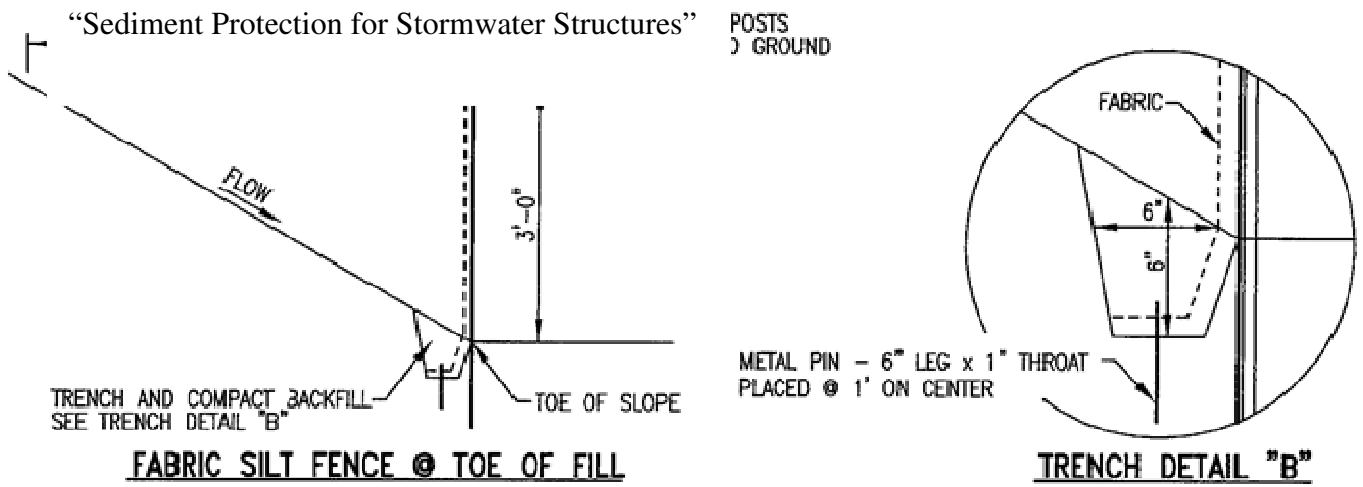

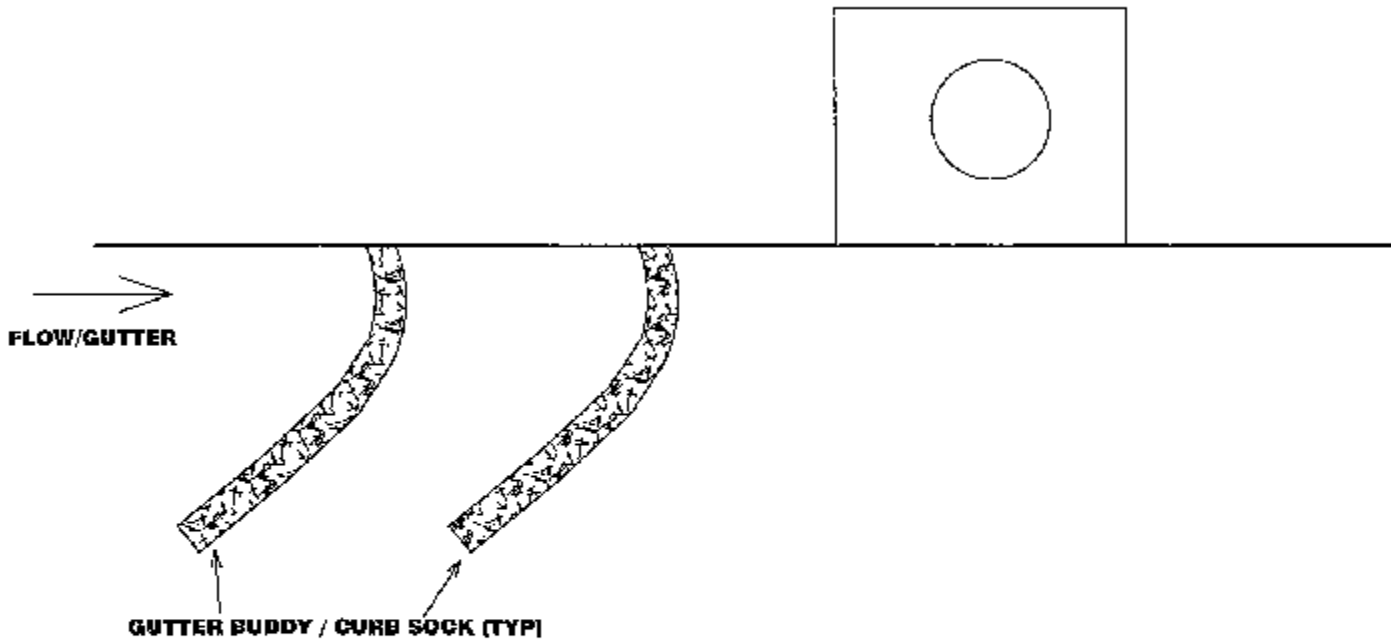

INLET PROTECTION DETAIL

DETAIL NOT TO SCALE

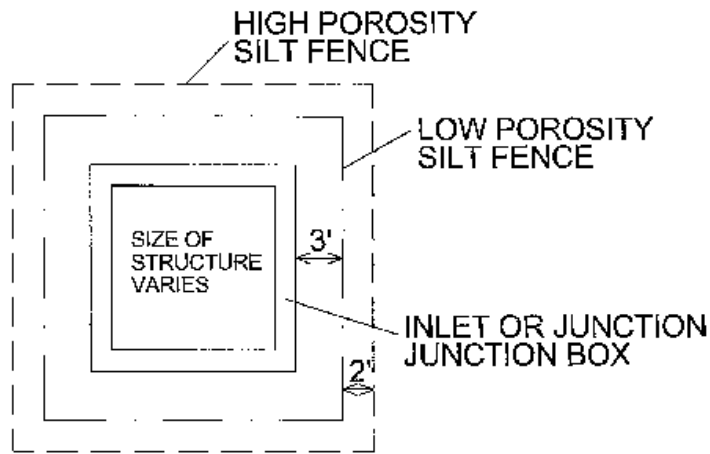

- SILT FENCE TO BE 30" ABOVE GRADE.
- FOR EACH STEEL STUDDED "T" LINE POST, 3 PLASTIC CABLE TIES ARE REQUIRED.

SILT FENCE DETAIL

DETAIL NOT TO SCALE